

# Measurement and Test Methods

## Electrical performance

### [Total Resistance]

With the shaft (lever) placed at the termination of terminal 1 or 3, total resistance shall be determined by measuring the resistance between the resistor terminals 1 and 3 unless otherwise specified.

### [Rated Power]

Rated power shall be the maximum value of electric power that can be applied continuously to the whole area of a resistor (between terminals 1 and 3) at the rated ambient temperature.

The rated ambient temperature of a carbon film resistor shall be 50°C. The maximum power at an ambient temperature of 50 to 70°C shall be obtained by multiplying the rated power by the rated power ratio determined from the derating curve shown below.

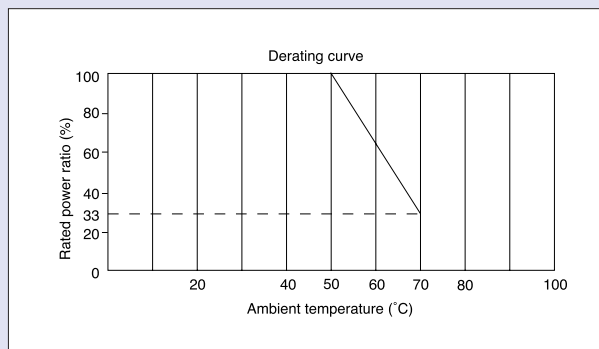

### [Rated Voltage]

Rated voltage is associated with the rated power and shall be determined by the following equation. When the resulting rated voltage exceeds the maximum operating voltage of a specific resistor, the maximum operating voltage shall be taken as the rated voltage.

$$E = \sqrt{P \cdot R}$$

E : rated voltage (V)  
P : rated power (W)  
R : total nominal resistance (Ω)

### [Tap Resistance]

Determined by measuring the resistance between a tap terminal and a specified terminal (terminal 1 or terminal 3).

### [Residual Resistance]

With the shaft (lever) placed at the termination of terminal 1, the resistance shall be measured between the terminals 1 and 2. Next, with the shaft (lever) placed at the end of terminal 3, the resistance shall be measured between the terminals 2 and 3. If there are tap terminals, the shaft (lever) shall be turned (moved) and the resulting minimum resistance between the tap terminal and the terminal 2 shall be measured.

### [Maximum Attenuation Level]

With the shaft placed at the termination of terminal 1, maximum attenuation level shall be determined by measuring the voltage applied between the terminals 1 and 2, and calculating the ratio to the voltage applied between the terminals 1 and 3.

Unless otherwise specified, the value obtained shall be used in place of the residual resistance of a rotary potentiometer for volume control.

### [Insertion Loss]

With the shaft placed at the termination of terminal 3, insertion loss shall be determined by measuring the voltage applied between the terminals 1 and 2 and calculating the ratio to the voltage applied between the terminals 1 and 3.

Unless otherwise specified, the value obtained shall be used in place of the residual resistance of a rotary potentiometer for volume control.

**[Sliding Noise]**

Measured by connecting the resistor to an amplifier having frequency characteristics specified in JIS C 6443, applying DC voltage of 20V between the terminals 1 and 3(if rated voltage is 20V or less, this voltage shall be applied) and by rotating (moving) the shaft (lever) at a speed of about 30 cycles per minute.

**[Voltage Withstand]**

Determined by applying AC voltage to the specified locations for one minute and checking for any arc, burning, dielectric breakdown and other abnormalities. Respective terminals may be tested together. The locations described below shall be tested unless otherwise specified. However, if the section concerned is so constructed as to conduct, that particular part shall not be tested.

**[Insulation Resistance]**

Measured with a megger by applying specified voltage to the specified locations. The locations below shall be tested unless otherwise specified. However, if the section concerned is so constructed as to conduct, that particular part shall not be tested.

**[Measuring Locations for Withstand Voltage and Insulation Resistance]**

- Between terminal and shaft (lever)
- Between terminal and metal cover (frame)
- Between terminal connected to separate resistor element and terminal connected to another resistor element (of multi-ganged-unit)
- Between switch terminal and shaft
- Between switch terminal and resistance terminal
- Between switch terminal and metal cover

**[Gang Error]**

With the shaft (lever) placed in the specified position, gang error shall be determined by applying test voltage of 2 to 15V (sine-wave RMS value) between the terminals 1 and 3 at 1,000±200Hz and measuring the voltage between the resistor terminal 2 and the specified terminal (terminal 1 or 3) and then by using the following equation. If there are no questions on determination, DC voltage may be applied for this test.

$$\text{Gang error} = 20 \log \frac{V_2}{V_1}$$

Where, V<sub>1</sub>: Voltage between the reference resistor terminals 1 and 2(voltage between the terminals 2 and 3 if the resistance tapers are C, E and reverse D)

V<sub>2</sub>: Voltage between the non-reference resistor terminals 1 and 2(voltage between the terminals 2 and 3 if the resistance tapers are C, E and reverse D)

If there is a tap terminal, measurement shall be made by connecting a fixed resistor whose resistance is equivalent to 1/10 of the nominal total resistance between the tap terminal and the terminal 1(if the resistance taper is C, make connection between the tap terminal and the terminal 3).

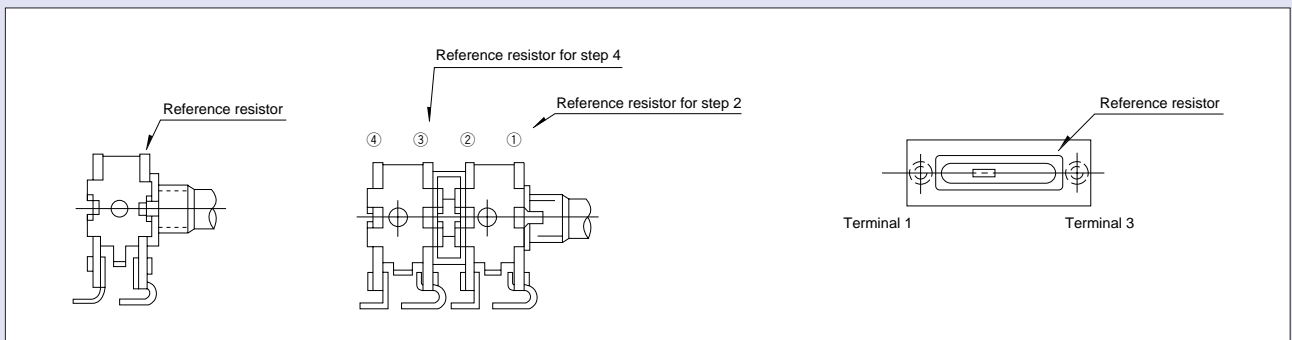

#### [Contact Resistance of Switch]

Unless otherwise specified, contact resistance of switch shall be determined by measuring drop voltage when 5V DC, 1A is applied between contacts and the contacts are closed.

## Mechanical Performance

---

#### [Total Rotational Angle (Travel)]

Determined by measuring the rotational angle (travel) when the shaft (lever) is turned (moved) from the termination position of terminal 1 to the termination position of terminal 3.

#### [Rotational Torque (Operating Force)]

Determined by measuring the torque (operating force) necessary to turn (move) the shaft (lever). Unless otherwise specified, measurement shall be made at an ambient temperature of 5 to 35°C, and the shaft rotational speed shall be 60° per second and the lever moving speed 20mm per second.

#### [Starting Torque (Starting Force)]

Determined by measuring a torque (operating force) necessary to turn (move) the shaft (lever) for the first time after allowing the test piece to stand for a long period of time. Unless otherwise specified, measurement shall be made at an ambient temperature of 5 to 35°C, and the shaft rotational speed shall be 60° per second and the lever moving speed 20mm per second.

Remarks: To be specified only when required in particular

#### [Shaft Wobble]

Determined by measuring the amount of deflection at a position of 30mm from the reference surface with a bending moment of 0.1N·m (50mN·m for insulated shaft) applied perpendicularly to the shaft from 180° different directions at a point within 3mm from the place where a smooth cylindrical surface of the shaft ceases to exist. However, if the length of the shaft is less than 30mm, proportional calculation shall be used.

#### [Allowable Operating Torque for Shaft (Lever)]

With the shaft (lever) placed at the termination of terminal 1, a specified torsional moment (force) shall be applied in that direction for 10 seconds. Next, the shaft (lever) shall be placed at the termination of terminal 3 and a specified torsional moment (force) shall be applied similarly, to check the control part and other related sections for any deformation or breakage.

#### [Push-pull Strength (Lever Push-pull Strength)]

A specified force shall be applied in the axial direction of the shaft (lever) for 10 seconds to check the control part and other sections for any deformation or breakage and for operating condition.